

The record of Deinotheriidae from the Miocene of the Swiss Jura Mountains (Jura Canton, Switzerland)

¹ Gagliardi Fanny, ^{2,3} Maridet Olivier & ^{2,3} Becker Damien

¹ Biology, University of Neuchâtel, CH-2000 Neuchâtel, Switzerland; fanny.gagliardi@unine.ch

² Jurassica Museum, Route de Fontenais 21, CH-2900 Porrentruy, Switzerland; damien.becker@jurassica.ch, olivier.maridet@jurassica.ch [corresponding authors]

³ Earth Sciences, University of Fribourg, Chemin du Musée 6, CH-1900 Fribourg, Switzerland

Abstract:

The Miocene sands of the Swiss Jura Mountains, long exploited in quarries for the construction industry, have yielded abundant fossil remains of large mammals. Among Deinotheriidae (Proboscidea), two species, *Prodeinotherium bavaricum* and *Deinotherium giganteum*, had previously been identified in the Delémont valley, but never described. A third species, *Deinotherium levius*, from the locality of Charmoille in Ajoie, is reported herein for the first time in Switzerland. These occurrences are dated from the middle to the Late Miocene, correlating to the European Mammal biozones MN5 to MN9. The study is completed by a discussion on the palaeobiogeography of deinotheres at the European scale.

Key words: *Prodeinotherium*, *Deinotherium*, Bois de Raube Formation, Miocene, Jura, Switzerland.

Introduction

The order Proboscidea currently regroups large mammals whose common features include tusks and a long, muscular trunk. Within the superorder Afrotheria, its sister group is Sirenia (dugongs and manatees). Its extant representatives belong to the Elephantidae family with only three species of elephants living in Africa or Asia (*Loxodonta africana*, *Loxodonta cyclotis* and *Elephas maximus*). However, this order was much more diversified in the fossil record.

The Proboscideans have an African origin hypothetically with the stem genus *Eritherium*, found in the early Late Paleocene of Morocco (Gheerbrant 2009), and indubitably with other primitive forms as the small-sized *Numidotherium* or *Barytherium*, the first large-sized proboscidean  these primitive

forms were only found in the late Early Eocene, and the Late Eocene and Early Oligocene, respectively, of Africa (Tassy 1990, Sanders et al. 2010). It should be noted that the relationship of *Eritherium* is unresolved. After Gheerbrant et al (2018), it is sister group to either both the Proboscidea and Sirenia or to all tethytherians. The gomphotheres (*Gomphotheriidae*) and the deinotheres (*Deinotheriidae*) are the earliest proboscideans found outside of Africa in the fossil record. Their occurrence in Europe is linked to the Proboscidean Datum Event (*sensu* Tassy 1990) of the late Early Miocene (ca. 19.5-17.5 Ma; Göhlich 1999). This biogeographic event resulted from the counter clockwise rotation of Africa and Arabia plates leading to a collision with the Anatolian plate and the formation of a landbridge connecting Africa and Eurasia at the end of the Early Miocene (Rögl 1999a, b). This geographic change allowed remarkable terrestrial mammal exchanges including the gomphotheres and the deinotheres (e.g. Göhlich 1999, Sen 2013). Within the phylogeny of Proboscideans (Fig. 1), deinotheres are included in a clade composed only of forms typically weighing more than 1000 kg (mega herbivores) together with Elephantiformes (*Phiomia*, *Mammut americanum*, *Gomphotherium* and Elephantidae) of which they are the sister group (Hutchinson et al. 2011). The differentiation between deinotheres and Elephantiformes could have occurred as early as the end of the Eocene. However, phylogenetic relationships within the Deinotheriidae family remain uncertain to this day.

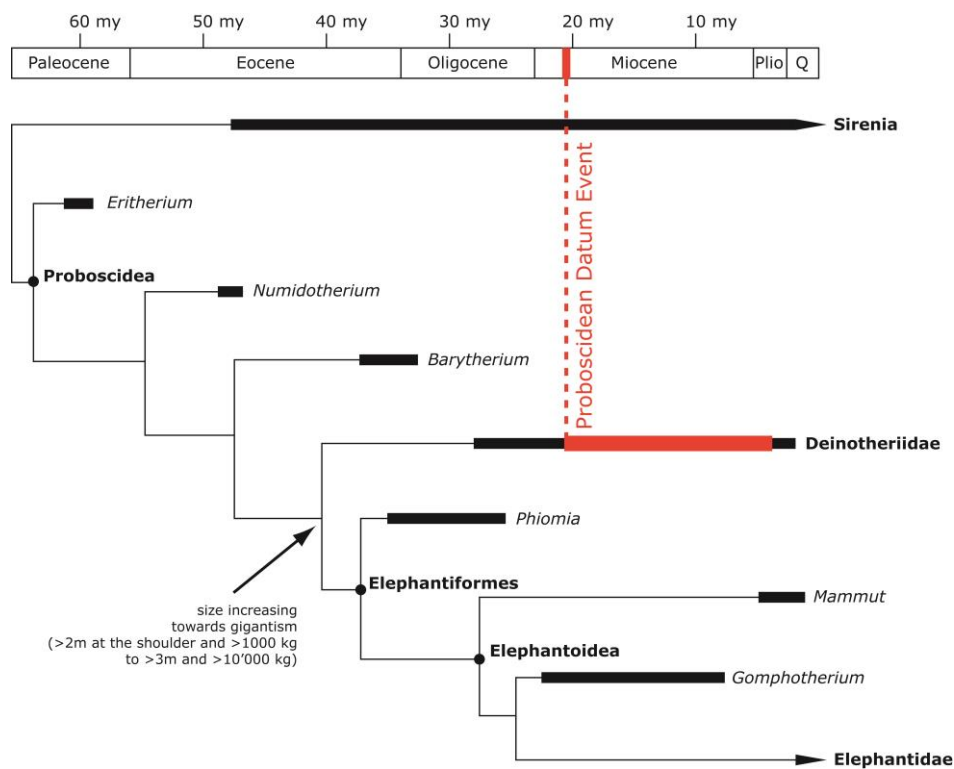



Figure 1. Simplified, stratigraphically calibrated, phylogeny of Proboscideans (modified from Hutchinson et al. 2011).

The oldest and most primitive deinotheres, *Chilgatherium harrisi* Sanders, Kappelman & Rasmussen, 2004, was discovered in Africa (Ethiopia) and is dated to the Late Oligocene (Sanders et al. 2004). It disappeared slightly before the Miocene, probably replaced by *Prodeinotherium hobleyi* (Andrews, 1911) recorded in Early Miocene of eastern Africa (Harris 1978, Pickford 2003, Sanders et al. 2010). After the *Proboscidean Datum Event* (ca. 19.5-17.5 Ma; late Early Miocene), the distribution of the family extends to Asia with *Prodeinotherium pentapotamiae* (Falconer, 1868) discovered in Pakistan (Welcomme et al. 1997) and to Europe with *Prodeinotherium cuvieri* Kaup, 1832 in Greece (MN3; specimens from Lesvos Island identified as *Prodeinotherium bavaricum* (von Meyer, 1831) by Koufos et al. 2003, but corrected in *P. cuvieri* following criteria of Ginsburg & Chevrier 2001 and Pickford & Pourabrishami 2013) as well as in France and Spain (MN4; Azanza et al. 1993, Ginsburg & Chevrier 2001). The last deinotheres are still present in Asia by the Late Miocene with *Deinotherium giganteum* Kaup, 1829, *Deinotherium proavum* (Eichwald, 1831) (= *D. gigantissimum*) and *Deinotherium indicum* Falconer, 1845 (Chaimanee et al. 2004, Rai 2004; Singh et al. 2020). In Africa, they persist with *Deinotherium bozasi* Arambourg, 1934 until the Early Pleistocene (Harris 1983, Harris et al. 1988). In the fossil record of Europe, three species seemed to occur during the Middle Miocene, although few evidences exist of an actual coexistence in fossil assemblages (e.g. Duranthon et al. 2007): *Prodeinotherium bavaricum* (= *P. hungaricum*)  *Deinotherium levius* Jourdan, 1861 and *Deinotherium giganteum* (e.g. Göhlich 1999, Ginsburg & Chevrier 2001, Pickford & Pourabrishami 2013). The latter survived until the end of the Vallesian, whereas during the Turolian *Deinotherium proavum* was the last representative of deinotheres in Europe (e.g. Codrea et al. 2002, Kovachev & Nikolov 2006, Boev & Spassov 2009, Konidaris et al. 2017).

From the Swiss Jura Mountains, Bachmann (1875) described a deinotheres mandible in five fragments, discovered in the west of the Montchaibeux hill by Jean-Baptiste Greppin in 1869, which he referred to "*Deinotherium*" *bavaricum*. Greppin (1867, 1870) reported the presence of a lower molar of *Deinotherium giganteum*, discovered by the geologist and naturalist Peter Merian in 1858, in the forest of Bois de Raube of the Delémont valley. Deinotheres and gomphotheres were also found in Charmoille and successively reported by Stehlin (1914), Schäfer (1961) and Kälin (1993). However, none of the deinotheres remains from Charmoille have ever been described. Additionally, an isolated upper molar labelled "*Deinotherium*" *bavaricum* is housed in the Jurassica Museum collections. This specimen has never been reported before and its exact origin in the Delémont valley remains uncertain. This study focuses on the fossil remains of deinotheres discovered in the Swiss Jura Mountains in order to provide a complete description of the specimens and to update their identifications. A discussion on the distribution of deinotheres throughout the Miocene of Europe completes the article.

Geographic, geologic and stratigraphic framework

The Jura Canton lies at the palaeogeographic junction between the Cenozoic tectonic and sedimentary provinces of the Upper Rhine Graben and the North Alpine Foreland Basin (Sissingh 2006). The regional fluvio-lacustrine sediments of the Miocene Bois de Raube Formation (OSM; Obere Süsswassermolasse = Upper freshwater molasse), were deposited both in Delémont Basin (near Delémont) and in Ajoie area (near Porrentruy). According to Kälin (1997), this formation is subdivided into three members differing by a markedly different heavy mineral spectrum and pebble content: a basal Montchaibeux Member (“Rote Mergel und Dinotheriensande des Mont Chaibeux” of Liniger 1925), a middle conglomeratic Bois de Raube Member (“Vogesenschotter des Bois de Raube” of Liniger 1925) in Delémont Basin, and an upper Ajoie Member (“Hipparionsande von Charmoille” of Liniger 1925). The formation covers the biochronological interval MN4 to MN9 (Kälin 1997, Choffat & Becker 2017, Prieto et al. 2017) and includes three historical localities that yielding deinotherere remains (Greppin 1867, 1870; Stehlin 1914; Schäfer 1961; Kälin 1993): Montchaibeux (MN5-6) in Rossemaison, Bois de Raube (MN7/8) in Develier, and Charmoille (MN9) in Ajoie (Fig. 2).

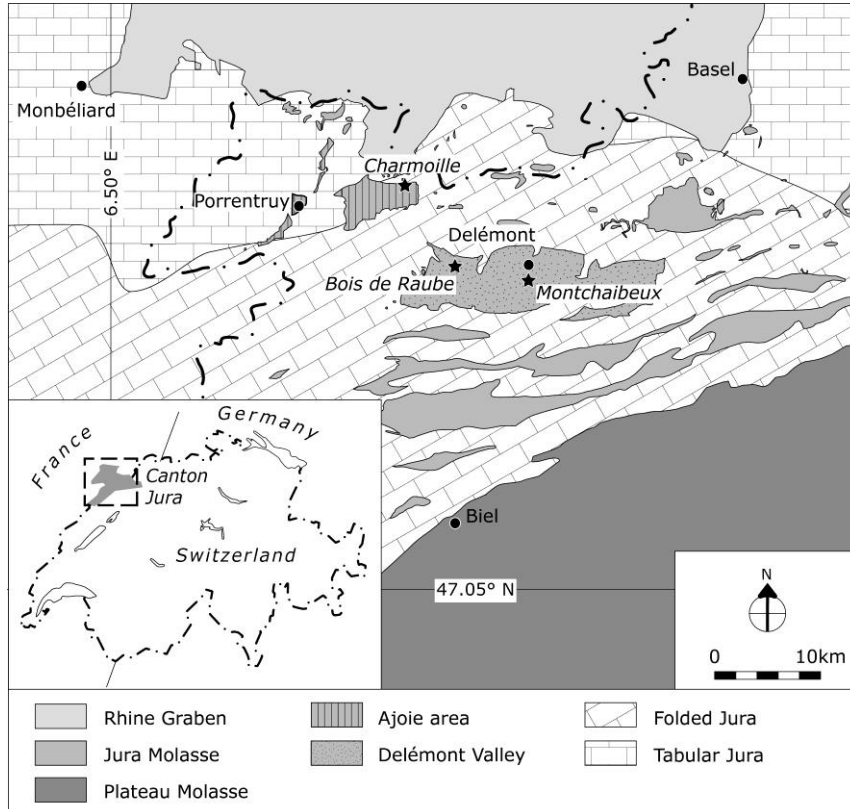

Figure 2. Geographic and geologic context of the Swiss Jura localities (Montchaibeux, Bois de Raube and Charmoille) with Deinotheriidae remains.

Material and method

Material

The studied material of Deinotheriidae, coming exclusively from in the Swiss Jura Canton, includes:

(1) the famous reconstituted mandible of *Prodeinotherium bavaricum* from the Montchaibeux locality (Bachmann 1875). A copy of this mandible is housed in the collections of the Jurassica Museum whereas the original specimen is housed in the collections Natural History Museum of Bern; (2) a copy of the lower molar of *Deinotherium giganteum* from the Bois de Raube locality (Greppin 1867, 1870), housed in the Jurassica Museum and whose the original seems to be housed in the Jean-Baptiste Greppin collection of Strasbourg University; (3) the upper molar of the Jurassica Museum collection of *Prodeinotherium bavaricum* coming probably from the Delémont valley; and (4) the specimens of Deinotheriidae from Charmoille (Stehlin 1914, Schäfer 1961, Kälin 1993, 1997, Choffat & Becker 2017) which consists in some fragments of tusks from the Jurassica Museum collection and more complete dental specimens housed in the Museum of Natural History of Basel.

Terminology and measurements

The dental terminology for Deinotheriidae mainly follows that of Aiglstorfer et al. (2014) and Pickford & Pourabrishami (2013) (Fig. 3), and is illustrated in this paper for a better understanding of the character descriptions and discussions. The measurements written in the tables or in the text are given in millimetres (precision at 0.1 mm), those in brackets are estimated.

Systematics

The taxonomy of Deinotheriidae is still a debated issue as there is no consensus in the literature about the valid genera and species. Some authors point to very conservative morphological features of deinotheres and evolutionary changes essentially characterized by a gradual size increase through time, referring to *Deinotherium* as the only valid genus (e.g. Gräf 1957, Ginsburg & Chevrier 2001, Pickford & Pourabrishami 2013). Others follow the two genera concept, *Prodeinotherium* and *Deinotherium*, as proposed by Éhik (1930), based on dental, cranial and postcranial features (e.g. Harris 1973, 1978, Gasparik 1993, Huttunen 2002a, Huttunen & Göhlich 2002, Duranthon et al. 2007, Vergiev & Markov 2010, Aiglstorfer et al. 2014, Konidaris et al. 2017, Göhlich 2020). The recent data of European deinotheres support five different morphospecies or chronospecies (Böhme et al. 2012, Pickford & Pourabrishami 2013), whereas previous investigations were favourable to four species (Gasparik 1993, 2001, Markov 2008, Vergiev & Markov 2010) or even two species (Huttunen 2002a).

Resolving this issue is beyond the goal of this study. Hence, following the most recent publications on deinotheres such as Aiglstorfer et al. (2014), Konidaris et al. (2017) and Göhlich (2020), this study refers to the two-genera taxonomic scheme and considers five European species to be valid: *Prodeinotherium cuvieri* (Kaup, 1832), *Prodeinotherium bavaricum* (von Meyer, 1831), *Deinotherium levius* Jourdan, 1861, *Deinotherium giganteum* Kaup, 1829 and *Deinotherium proavum* (Eichwald, 1831).

upper check teeth

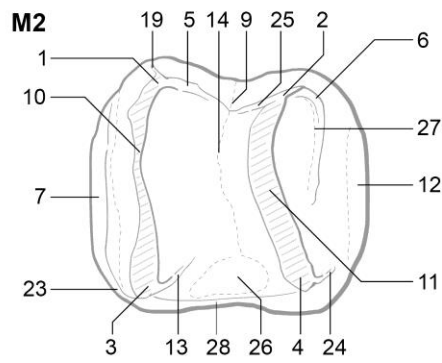
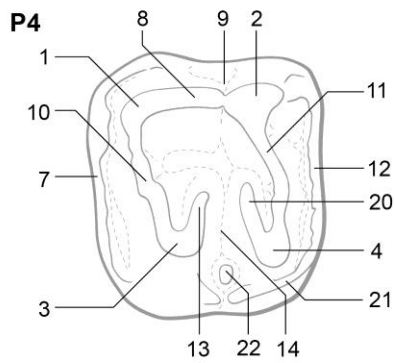
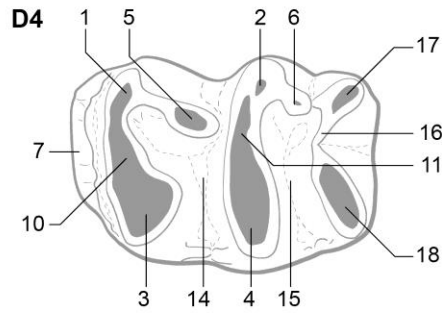

lower check teeth

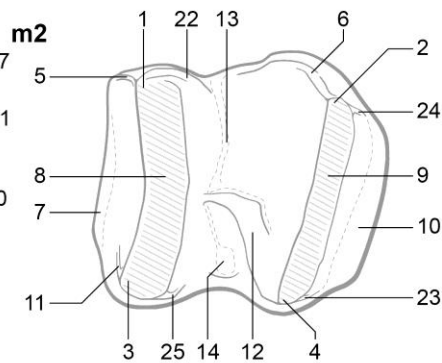
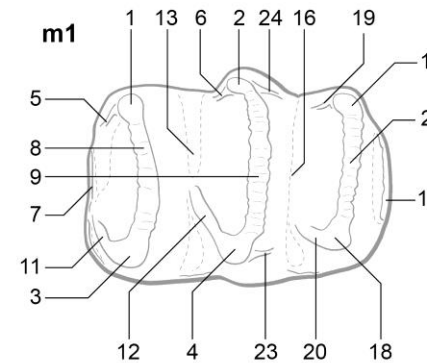
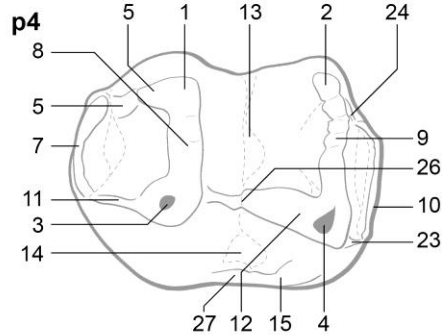

Figure 3. Dental terminology of upper and lower cheek teeth of Deinotheriidae in occlusal views (not to scale), mainly following Aiglstorfer and al. (2014) and Pickford & Pourabrishami (2013). **Upper cheek teeth:** 1, paracone; 2, metacone; 3, protocone; 4, hypocone; 5, postparacrista; 6, postmetacrista; 7, anterior cingulum; 8, ectoloph; 9, ectoflexus; 10, protoloph; 11, metaloph; 12, posterior cingulum; 13, postprotocrista; 14, median valley; 15, distal valley; 16, tritoloph; 17, labial tritoloph cone; 18, lingual tritoloph cone; 19, praeparacrista; 20, praehypocrista; 21, lingual cingulum; 22, entostyle (mesostyle of Harris 1973); 23, praeprotocrista; 24, posthypocrista; 25, praemetacrista; 26, lingual medifossette; 27, convolute; 28, lingual cingulum. **Lower cheek teeth:** 1, metaconid; 2, entoconid; 3, protoconid; 4, hypoconid, 5, praemetacristid; 6, praeentocristid; 7, anterior cingulid; 8, metalophid; 9, hypolophid; 10, posterior cingulid; 11, praeprotocristid; 12, praehypocristid; 13, median valley; 14, labial medifossette; 15, labial cingulid; 16, distal valley; 17, lingual tritolophid conid; 18, labial tritolophid conid; 19, anterior cristid of the lingual tritolophid conid; 20, anterior cristid of the labial tritolophid conid; 21, tritolophid; 22, postmetacristid; 23, posthypocristid; 24, postentocristid; 25, postprotocristid; 26, labial notch; 27, labial cingulid

Stratigraphy and fossil record

The stratigraphical framework used in this study is based on the global geological time scale for the Neogene (Hilgen et al. 2012), the European Mammal Neogene units (MN-Zones; Mein 1999, Steininger 1999), and the Swiss fauna references (Engesser & Mödden 1997, Berger 2011).

The data set of the fossil record of the European deinotheres is a compilation of the localities reported in Maridet & Costeur (2010), The Paleobiology Data Base (extraction the 25.07.2019 with the parameter family = Deinotheriidae) and additional literature (Appendix). In order to highlight the palaeobiogeographic dynamics of distribution of deinotheres in Europe, localities are grouped by the biochronological intervals MN4-5, MN6-8, MN9-12 and MN13-14, and biogeographic events (Proboscidean Datum Event, Hipparion Datum Event) and major climate changes (Miocene Climatic Optimum, Mid-Miocene Cooling Event, Messinian Crisis) are taken into account. The biostratigraphical correlation of each locality was systematically checked in the literature and questionable data were removed from the data set.

Abbreviations

APD anteroposterior diameter, **dex.** right, **H** height, **i** lower incisors, **L** length, **m/M** lower and upper molars, **MJSN** Jurassica Museum (formerly Musée jurassien des Science naturelles), **MN** Mammal Neogene, **NMB** Naturhistorisches Museum Basel, **NMBE** Naturhistorisches Museum Bern, **p/P** lower and upper premolars, **sin.** left., **TD** transverse diameter, **W** width.

Systematic

Class MAMMALIA Linnaeus, 1758

Order PROBOSCIDEA Illiger, 1811

Family Deinotheriidae Bonaparte, 1845

Genus *Prodeinotherium* Ehik, 1930

European species: *Prodeinotherium bavaricum* (von Meyer, 1831), *P. cuvieri* Kaup, 1832.

***Prodeinotherium bavaricum* (von Meyer, 1831)**

(Figs. 4-5; Tab. 1-3)

Stratigraphical range

Late Early and Middle Miocene, MN5-6 (Böhme et al. 2012, Pickford & Pourabrishami 2013, Konidaris et al. 2017, Göhlich 2020).

Material referred

M2 dex. (MJSN-VDL-001) from the Delémont valley (unknown locality); P4 dex. (NMB-Mch.4, copy MJSN-MTC-001) and mandible with i2 and p4-m3 (NMBE-5031977, copy MJSN-MTC-002) from Montchaibeux.

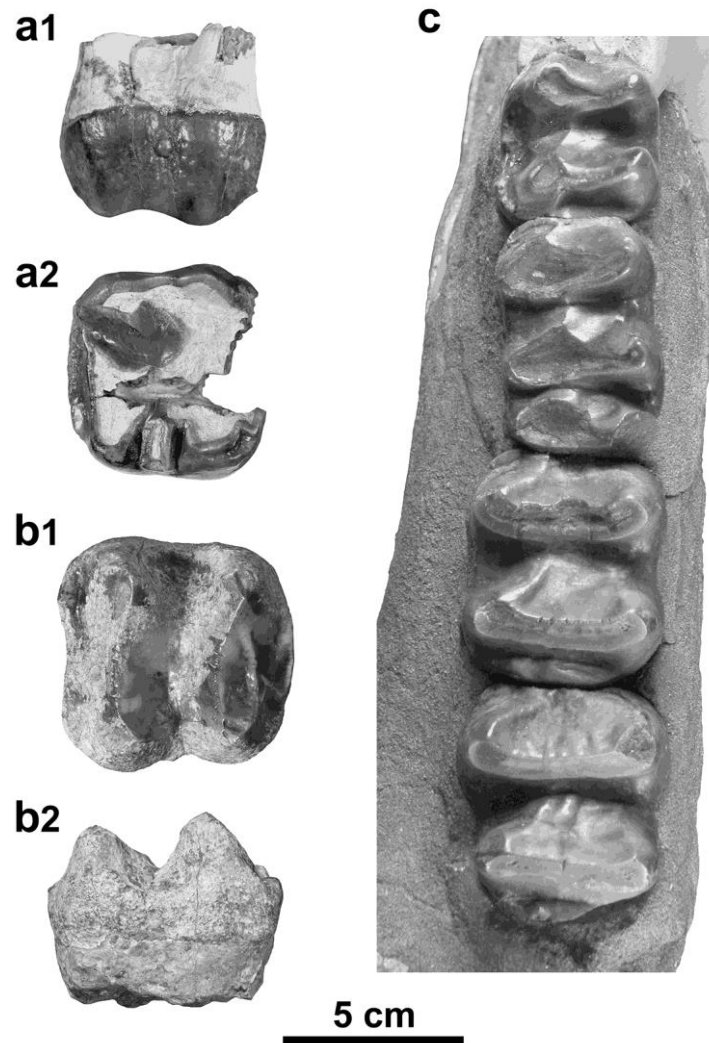

Figure 4. *Prodeinotherium bavaricum* from the Delémont valley (Jura, Switzerland). **a**, P4 dex. (NMB-Mch.4, Montchaibeux locality) in labial (a1) and occlusal (a2) views; **b**, M2 dex. (MJSN-VDL-001, unknown locality) in occlusal (b1) and labial (b2) views; **c**, p4-m3 sin. (NMBE-5031977, Montchaibeux locality) in occlusal view. Scale bar = 5 cm.

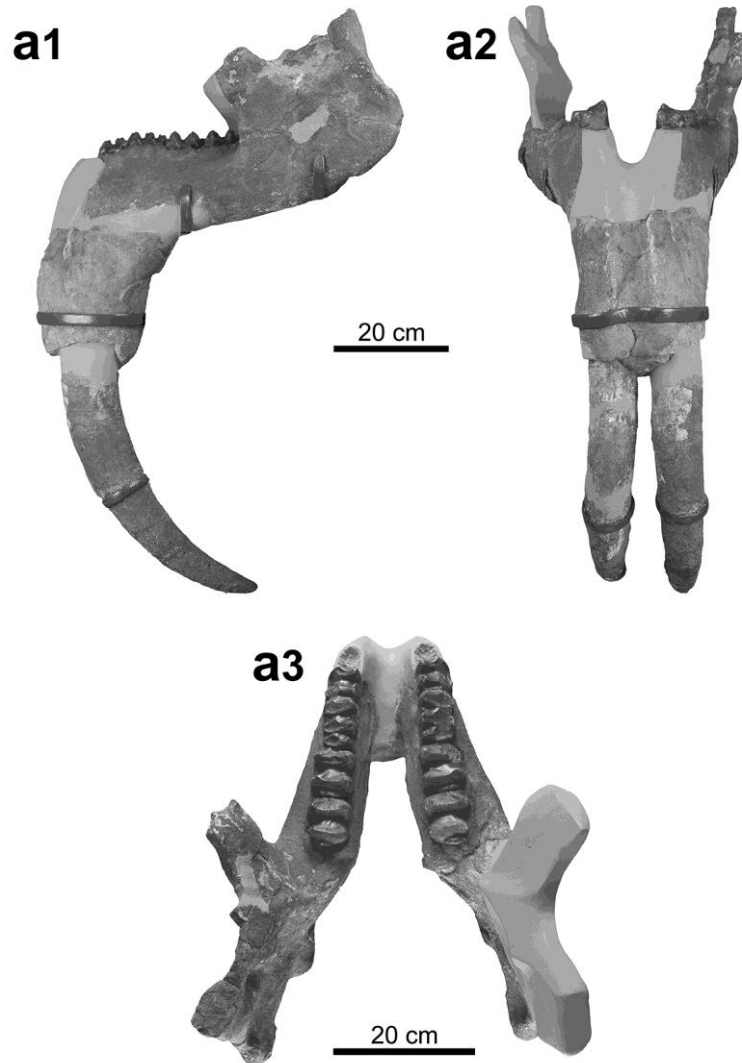

Figure 5. *Prodeinotherium bavaricum* from Montchaibeux (Jura, Switzerland). **a**, Mandible (NMBE-5031977) in lateral view (a1), in anterior view (a2) and in dorsal view (a3). Scale bar = 20 cm.

Specimens	Length	Width		Height
		protoloph	metaloph	
NMB-Mch.4 (P4)	53.9	58.5	56.1	28.8
MJSN-VDL-001 (M2)	66.5	65.6	62.2	35.0
NMB-D.G.5 (M2)	61.8	64.2	66.7	-
NMB-Fa.129 (M2)	64.3	68.3	61.2	-
NMB-Fa.167 (M2)	71.8	70.5	70.9	-

Table 1. Dimensions [mm] of P4 and M2 of *Prodeinotherium bavaricum* (NMB-Mch.4, Montchaibeux, MN5-6; MJSN-VDL-001 Delémont valley, Middle Miocene; NMB-D.G.5, Haute Garonne of Aurignac, Middle Miocene; NMB-Fa.129, NMB-Fa.167, Pontlevoy-Thenay, MN5).

Measurements	Sin.	Dex.
Height of the mandibular ramus	260.0	-
Length of tooth row	290.0	290.0
Height of mandibular body at m2 and m3	155.0 ; 165.0	135.0 ; 165.0
Width of mandibular body at p4, m1, m2 and m3	90.0 ; 95.0 ; 105.0 ; 120.0	90.0 ; 100.0 ; 115.0 ; 130.0
Length of the mandibular ramus	26.0	-

Table 2. Dimensions [mm] of the mandible of *Prodeinotherium bavaricum* (NMBE-5031977) from Montchaibeux (Jura, Switzerland, MN5-6).

Incisors	Antero-posterior diameter	Transversal diameter	Length		
i2 sin. (tusk)	285.0	120.0	535.0		
i2 dex. (tusk)	285.0	130.0	475.0		
Cheek teeth	Length	Width			Height
		metalophid	hypolophid	tritolophid	
p4 sin.	53.1	43.4	46.4	-	29.5
p4 dex.	50.9	44.7	46.3	-	30.4
m1 sin.	67.0	44.3	44.9	41.9	22.7
m1 dex.	69.5	46.7	47.4	48.8	31.2
m2 sin.	61.9	55.3	55.7	-	30.2
m2 dex.	64.9	(58.5)	59.0	-	33.5
m3 sin.	64.3	56.8	50.7	-	27.7
m3 dex.	68.2	64.7	53.1	-	33.5

Table 3. Dimensions [mm] of the teeth of the mandible *Prodeinotherium bavaricum* (NMBE-5031977) of Montchaibeux (Jura, Switzerland, MN5-6).

Description

The P4 is damaged anteriorly and moderately worn. It is nearly quadratic in occlusal view, just slightly wider than long. The ectoloph is complete bearing an ectoflexus weakly developed, and distinct paracone fold, mesostyle (intermediate fold) and metacone fold, the former being the most developed. The protocone seems to extend labially, forming a complete protoloph reaching the paracone. The hypocone is labially elongated but does not form a complete metaloph connecting to the metacone, giving a sublophodont morphology to the tooth. The cingulum is posteriorly pronounced but anteriorly unobservable. The labial one is absent whereas the lingual one is strong but only present at the level of the protocone. The lingual opening of the median valley bears a well-developed entostyle. Three roots are present; the unique lingual one results from the fusion of two roots.

The M2 is bilophodont and subquadrate in occlusal view. The protoloph and metaloph are complete, both with almost the same width, anteriorly convex (with a more pronounced convexity on the metaloph) and have anterior wear facets. The four main cusps are distinct from the lophes. The postparacrista is well-marked and slopes to the median valley that is opened on the lingual side. The postprotocrista is less developed and does not extend downward to the medial valley. The praehypocrista and the posthypocrista are not marked. The praemetacrista is well pronounced, slopes to the median valley and joins the postparacrista. Posteriorly, the convolute is well-developed. The anterior and posterior cingula are strong and continuous, although the anterior one is thinner in its middle part. The lingual cingulum is less pronounced but closes the lingual medifossette. The labial side of the tooth lacks any cingulum, but it is characterised by a deep ectoflexus.

The mandible NMBE-5031977, restored from 5 fragments, is incomplete. The ramus is low and slightly inclined forward, the mandibular angle and has an elevated position, the base of the corpus is straight, and the posterior margin of the symphysis is located below the front of the p4. The i2 are oriented downward and slightly curved backwards in their distal parts. The tooththrows are almost complete from p4 to m3, the p4s being anteriorly incomplete and the p3 not preserved. The m1s are trilophodont and the other lower cheek teeth are bilophodont. The transverse lophids are subparallel, posteriorly convex for the anterior ones to straight for the posterior ones, and possess wear facets posteriorly oriented.

In occlusal view, the p4 is rectangular, longer than wide. The paracristid is not preserved, the metalophid is posteriorly convex and the hypolophid is almost straight. The ectolophid is poorly developed and descends anterolingually to reach the median valley. The labial cingulid is reduced to the posterior part of the tooth, the lingual one is lacking. The posterior cingulid is well developed, continuous and low but merging with a weak posthypocristid.

The rectangular m1 is trilophodont, with sub-parallel, roughly straight and of equally wide transverse lophids. The praeprotocristid, the praehypocristid and the anterior cristid of the labial tritolophid conid are all well pronounced, the latter two reaching the bottom of the respective front valleys. The anterior and posterior cingulids are poorly developed whereas the labial and lingual ones are lacking. The m2 is sub-rectangular in occlusal view, slightly longer than wide, with equally wide transverse lophids. The metalophid is posteriorly slightly convex and the hypolophid is straight. The praeprotocristid and the praehypocristid are well developed and anterolingually oriented, the former reaching the bottom of the median valley. The anterior and posterior cingulids are continuous, the posterior one being stronger. The lingual and labial cingulids are lacking.

The m3 is morphologically similar to the m2. However, the hypolophid is slightly reduced in width compared to the metalophid and the posterior cingulid is more pronounced but strongly reduced in width, giving a longer and trapezoidal outline in occlusal view.

Comparisons

The referred dental remains are typical of the Deinotheriidae family with mainly bilophodont jugal teeth associated to a sublophodont (well-developed ectoloph and incomplete metaloph) P4 and a trilophodont m1, as well as i2 oriented downwards and backwards (Huttunen 2002a).

The specimens differ from *Deinotherium proavum* and *D. giganteum* by their considerably smaller dimensions (Gräf 1957, Tobien 1988, Vergiev & Markov 2010, Pickford & Pourabrishami 2013, Aiglstorfer et al. 2014, Ţibuleac 2018). *Deinotherium levius* also presents larger dimensions (Fig. 6), but the differences are less significant (Gräf 1957, Tobien 1988, Pickford & Pourabrishami 2013). However, the strong development of the convolute and the near absence of postprotocrista and posthypocrista on the M2 clearly exclude an attribution to *Deinotherium* (Harris 1973, Huttunen 2002b, Poulakakis et al. 2005, Duranthon et al. 2007, Aiglstorfer et al. 2014). Likewise the moderately developed curve of the i2 can be distinguished from the more pronounced one of *D. giganteum* and the subvertical one of *D. levius* (Gräf 1957) and the position of the mandibular angle is more elevated than that of *Deinotherium* species (see Gräf 1957, fig. 12, Svistun 1974, pl. 1, Huttunen & Göhlich 2002, fig 3, Vergiev & Markov 2010, figs. 3-4; Iliopoulos et al. 2014, fig. 1).

Although, in *Prodeinotherium*, the entostyle is usually lacking on P3-4 and the metaloph usually complete on P4, these particular characters, present on the referred P4 NMB-Mch.4, can be attributed to generic variability (e.g. Harris 1973, Ginsburg & Chevrier 2001, Aiglstorfer et al. 2014). Also by its dimensions, the almost absence of an ectoflexus and the quadratic outline in occlusal view, this specimen shows strong similarities with *P. bavaricum* (Ginsburg & Chevrier 2001, Duranthon et al. 2007, Pickford & Pourabrishami 2013). Based on the morphology of the P4 (nearly

absence of ectoflexus and the quadratic outline), the M2 (developed convolute) and the lower cheek teeth (m1 with transverse lophids roughly straight and of equal width), as well as the modest curve of the i2 and the more elevated position of the mandibular angle, the specimens can be referred to the genus *Prodeinotherium* (Gräf 1957, Harris 1973, Huttunen 2002a, Huttunen & Göhlich 2002, Duranthon et al. 2007). Additionally, after Ginsburg & Chevrier (2001) and Pickford & Pourabrishami (2013), the specimens cannot be referred to the species *P. cuvieri* due to their larger dimensions, but rather to *P. bavaricum* of which the size is much closer (e.g. Gräf 1957, Kovachev & Nikolov 2006, Huttunen & Göhlich 2002).

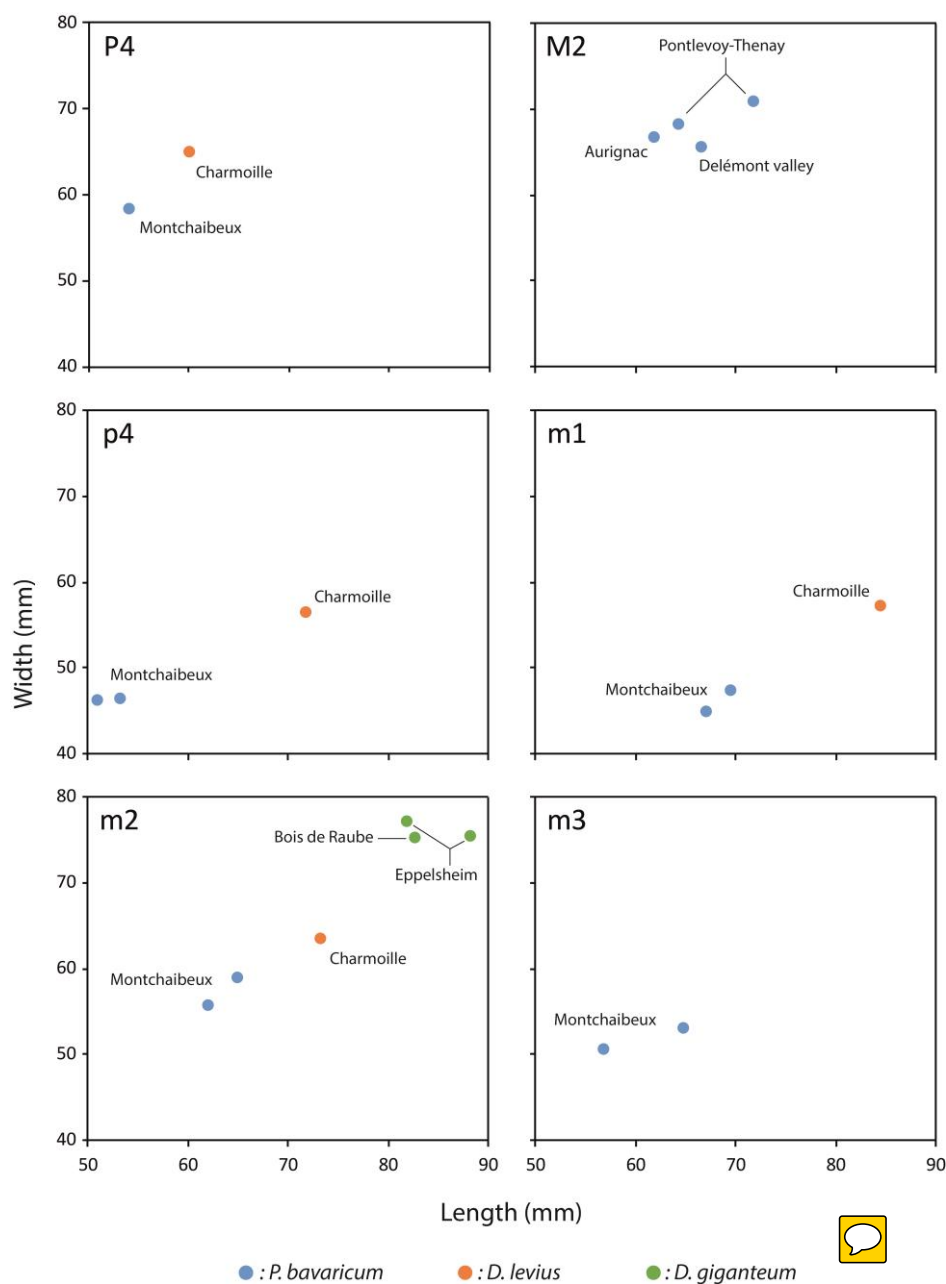

Figure 6. Scatter diagram of the size (in mm) of teeth studied herein.

Deinotherium Kaup, 1829

European species: *Deinotherium giganteum* Kaup, 1829, *D. proavum* (Eichwald, 1831), *D. levius* Jourdan, 1861.

***Deinotherium levius* Jourdan, 1861**

(Fig. 7; Tab. 4)

Stratigraphical range

Late Middle to early Late Miocene MN7/8-9 (Göhlich & Huttunen 2009, Aiglstorfer et al. 2014, Konidaris et al. 2017, Konidaris & Koufos 2019, this study).

Material referred

Distal fragment of a right incisor (NMB-Cm.478), D4 dex. (NMB-Cm.245, copy MJSN-CH-060), P4 dex. (NMB-Cm-96, copy MJSN-CH-062), p4 dex. (NMB-Cm.469, copy MJSN-CH-058), m1 dex. (NMB-Cm.466, copy MJSN-CH-059) and m2 dex. (NMB-Cm.737, copy MJSN-CH-061) from Charmoille in Ajoie.

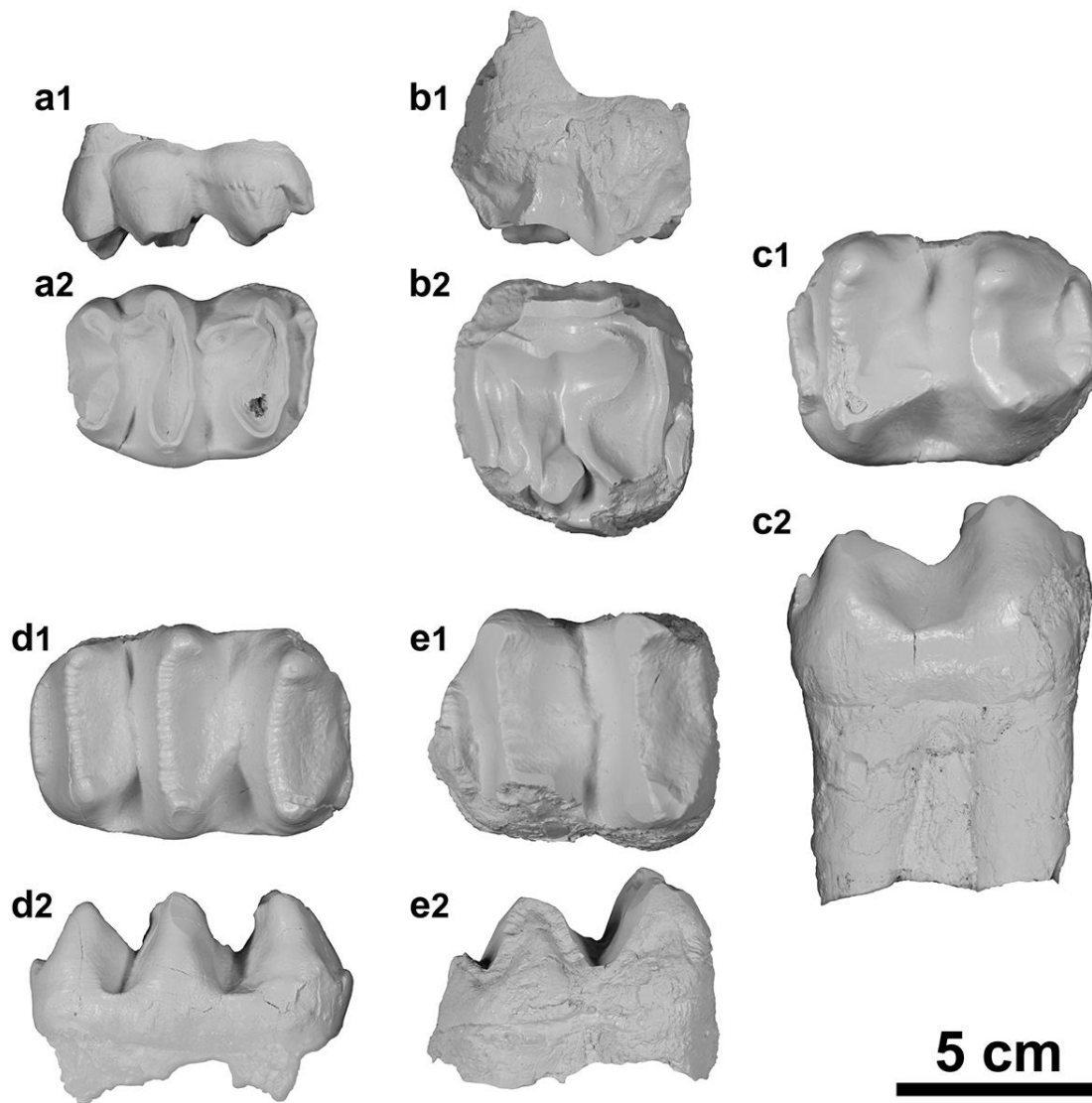

Figure 7. *Deinotherium levius* from Charmoille (Jura, Switzerland). **a**, D4 dex. (copy MJSN-CH-060 of NMB-Cm.245,) in labial (a1) and occlusal (a2) views; **b**, P4 dex. (copy MJSN-CH-062 of NMB-Cm-96,) in labial (b1) and occlusal (b2) views; **c**, p4 dex. (copy MJSN-CH-058 of NMB-Cm.469,) in occlusal (c1) and labial (c2) views; **d**, m1 dex. (copy MJSN-CH-059 of NMB-Cm.466,) in occlusal (d1) and labial (d2) views; **e**, m2 dex. (copy MJSN-CH-061 of NMB-Cm.737,) in occlusal (e1) and labial (e2) views. For better illustration quality, white copies have been photographed. Scale bar = 5 cm.

Upper check teeth	Length	Width		Height
		protoloph	metaloph	
NMB-Cm.245 (D4)	65.9	46.4	48.8	27.1
NMB-Cm.96 (P4)	(59.9)	(65.1)	(62.4)	37.7
Lower check teeth	Length	Width		Height
		metalophid	hypolophid	
NMB-Cm.469 (p4)	71.8	56.5	56.2	49.5
NMB-Cm.466 (m1)	84.5	55.1	57.2	36.5
NMB-Cm.737 (m2)	(73.2)	(63.6)	(61.1)	40.7

Table 4. Dimensions [mm] of the dental specimens of *Deinotherium levius* from Charmoille (Jura, Switzerland, MN9).

Description

The fragmented incisor NMB-Cm.478 is roughly oval in transverse section, with a longest axis in anteroposterior direction, the diameter diminishing distally and a flattened medial side. The distal curvature, caudally and laterally, is weakly developed. The specimen shows wear facets on the distal side and at the tip.

The D4 is trilophodont and elongated. The protoloph is anteriorly convex and the metaloph is nearly straight. The tritoloph is anteriorly strongly convex and incomplete, the lingual and labial cones are separated by a notch. The postparacrista and the postmetacrista are well-developed, extending posterolingually downward and reaching the rear loph. The anterior and posterior cingula are present, the anterior one being strongly pronounced and connected to the paracone by a faint crista. The transverse valleys are lingually faintly closed by a reduced lingual cingulum. The labial cingulum is almost completely lacking, only faint labial rugosities are observable at the level of the paracone.

The P4 is moderately worn, incomplete (enamel only partly preserved around the outline of the crown), slightly wider than long and trapezoidal in occlusal view. The ectoflexus is very smooth and the mesostyle barely distinct. The protoloph is complete, reaching the paracone, whereas the metaloph is in contact with the metacone but not fused with it. The hypocone extends anterolabially downward by a praehypocrista. The cingulum is absent labially, is anteriorly and posteriorly strong and continuous, and is labially reduced to the opening of median valley. The latter bears a strong entostyle in contact with the hypocone but separated from the protocone. The two lingual roots are isolated and the two lingual ones are in contact, just separated by a vertical groove.

The p4 is almost bilophodont with the occlusal outline longer than wide. An ectolophid extends anterolingually downward from the hypoconulid, reaching the base of the metalophid. The metalophid is anteriorly concave, the hypolophid is roughly straight. The paracristid extends anteriolingually downward from the paraconid and connects a very strong anterior cingulid. The praemetacristid extends anteriorly downward, almost closing an anterior valley-like groove. The posterior cingulid is well developed and connected to the hypoconulid by a very faint posthypocristid. The lingual cingulid is lacking and the labial one is reduced to the base of the labial notch, closing a labial medifossette.

The m1 is trilophodont and elongated. Each conid has a slightly pronounced anterior cristid. The praehypocristid is the most developed. It extends anteriolingually downward, reaching the anterior valley and reaching the metalophid. The anterior cingulid is poorly developed whereas the posterior one is more developed. The transverse valleys are open on both sides, although reduced labial cingulids are present at the extremities of these valleys.

The m2 is bilophodont and nearly rectangular (slightly longer than wide). The anterior cingulid is unobservable whereas the posterior one is low and strong but narrower than the hypolophid. The median valley is opened on both sides, without labial and lingual cingulids. Each conid has a slightly developed and anteriorly extending cristid, except the praehypocristid which extends anterolingually and reaches the bottom of the median valley.

Comparisons

The specimens from Charmoille show the typical features of Deinotheriidae: lower tusks oriented downward, P4 bearing an ectoloph, trilophodont D4 and m1, and a bilophodont pattern for the remainder of the cheek teeth (Huttunen 2002a). They differ from *Prodeinotherium* by being larger, by a trapezoidal outline and a more distinct ectoflexus in P4, as well as a narrower tritolophid compared to other lophids in m1 (Gräf 1957, Ginsburg & Chevrier 2001, Duranthon et al. 2007). Among the *Deinotherium* species, they display more affinities with *D. levius* by the size (slightly smaller than those of *D. giganteum*, Pickford & Pourabrishami 2013), by a subcomplete metaloph without a notch separating it from the metacone and the presence of a strong entostyle on P4, by a protolophid and metalophid of equal lengths in p4 (rectangular outline vs trapezoidal outline in *D. giganteum*), and by a short posterior cingulid on m2 (Gräf 1957, Duranthon et al. 2007). This attribution also seems to be supported by the i2 NMB-Cm478 that displays a sub-straight tusk tip, characteristic of *D. levius* according to Gräf (1957).

***Deinotherium giganteum* Kaup, 1829**

(Fig. 8; Tab. 5)

Stratigraphical range

Late Middle to early Late Miocene MN7/8-10 (Konidaris et al. 2017, this study).

Material referred

Complete m2 sin. (copy MJSN-BRA-001; original in the Jean-Baptiste Greppin collection at the Strasbourg university) from the Bois de Raube locality in the Delémont valley.

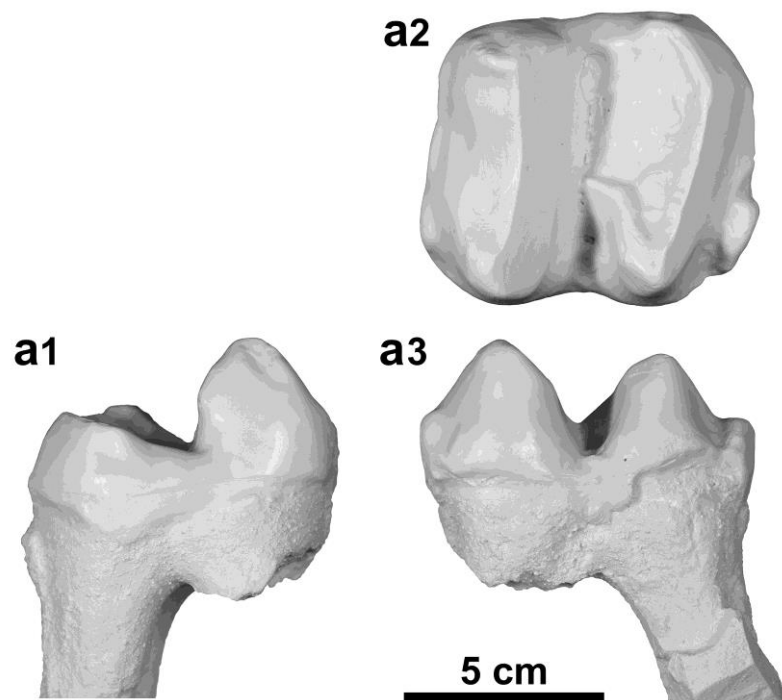

Figure 8. *Deinotherium giganteum* from Bois de Raube in the Delémont valley (Jura, Switzerland). **a**, m2 sin. (copy MJSN-BRA-001) in lingual (a1), occlusal (a2) and labial (a3) views. For better illustration quality, white copy has been photographed. Scale bar = 5 cm.

Specimens	Length	Width		Height
		metalophid	hypolophid	
MJSN-BRA-001	82.6	72.1	75.2	40.0
NMB-Ep.16	81.9	77.2	75.6	-
NMB-Ep.135	88.1	75.5	70.5	-

Table 5. Dimensions [mm] of m2 of *Deinotherium giganteum* (copy MJSN-BRA-001, Bois de Raube, Jura, Switzerland, MN6-7/8; NMB-Ep.16, NMB-Ep.135, Eppelsheim, Germany, MN9)



Description

The referred m2 is bilophodont and slightly longer than wide in occlusal view. The four main cuspids are distinct. The transverse lophids are complete, separated by a labially deeper median valley, and have posteriorly wear facets. The hypolophid is sublinear and slightly wider than the metalophid. The metalophid is anteriorly weakly concave. The protoconid and the metaconid are quite sharp and equally high. The prae- and postprotocristid are hardly distinct, the prae- and postmetacristid are more prominent but blunt. The entoconid is very smooth, difficult to distinguish and lower than the metaconid. The praeentocristid is quite well marked, very rounded, and descends almost to the level of the median valley. The postentocristid is barely visible. The hypoconid, quite salient at the top, is slightly more modest than the protoconid. The praehypocristid, really robust and smooth, forms a thick enamel bulge that descends transversally to the median valley level and almost reaches the middle of the tooth. The posthypocristid is very weak, almost indistinct. There is no particular ornamentation on the tooth. However, the presence of a strong posterior cingulid, incomplete on the labial side, of a weak anterior cingulid, slightly more pronounced labially, and of a labial medifossette barely delimited by a modest enamel bridge are noticeable.

Comparisons

The m2 displays a bilophodont pattern with a well-developed posterior cingulid which are typical of the Deinotheriidae family (Huttunen 2002a). This m2 can be differentiated from m2s of *Prodeinotherium* by their sizes (Fig. 6) that are on average up to more than 30% larger than those of *P. cuvieri* and about 20% larger than those of *P. bavaricum* (e.g. Gräf 1957, Ginsburg & Chevrier 2001, Huttunen & Göhlich 2002, Pickford & Pourabrishami 2013). In addition, the praehypocristid is remarkably more developed than in *P. bavaricum* (as is the posterior cingulid too), then the tooth can be undoubtedly referred to the genus *Deinotherium* (e.g. Huttunen 2002a, b, Huttunen & Göhlich 2002, Duranthon et al. 2007, Țibuleac 2018).

A specific identification within the genus *Deinotherium* remains very difficult based on morphological characters whereas size increase seems to be most obvious change interpreted as an evolutionary trend through time (e.g. Gräf 1957, Ginsburg & Chevrier 2001, Duranthon et al. 2007, Pickford & Pourabrishami 2013). However, Pickford & Pourabrishami (2013) suggest specific attributions by highlighting, contrary to Gräf (1957), discontinuous size ranges from one species to another. Based on these observations, m2s of *D. proavum* are always larger than 90 mm and can exceed 100 mm, which unambiguously excludes our specimen from Bois de Raube whose length is 82.6 mm (Tab. 5).

Deinotherium levius, with m2 lengths between 69.2 and  0 mm, is noticeably smaller. The m2 of Bois de Raube (MJSN-BRA-001) falls within the size range of *D. giganteum*, between 79.0 and 89.3 mm.  However, the degree of development of the posterior cingulid shows a very close similarity to m2 of *D. giganteum* from Eppelsheim (NMB-Ep.16, NMB-Ep.135) and from Romania (Țibuleac 2018). For these reasons, we tentatively refer this isolated tooth to *D. giganteum*. 

Discussion

Fossil record of Deinotheriidae in the Jura

The age of the deinotheres discovered in the Swiss Jura Mountains is based on the regional litho- and biostratigraphy established by Kälin (1993, 1997) and Prieto et al. (2017) and fits the biostratigraphic range of the species at the European scale. The records correlate to MN5-6(-7) for *P. bavaricum* in Montchaibeux, to MN7/8 for *D. giganteum* in Bois de Raube and to MN9 for *D. levius* in Charmoille. The latter record indicates the first report of *D. levius* in Switzerland and matches the latest occurrences of this species in Europe (Göhlich & Huttunen 2009, Aiglstorfer et al. 2014, Konidaris & Koufos 2019), whereas the  record of *D. giganteum* in Bois Raube could be among the youngest record of this taxa in Europe. (Fig. 9).

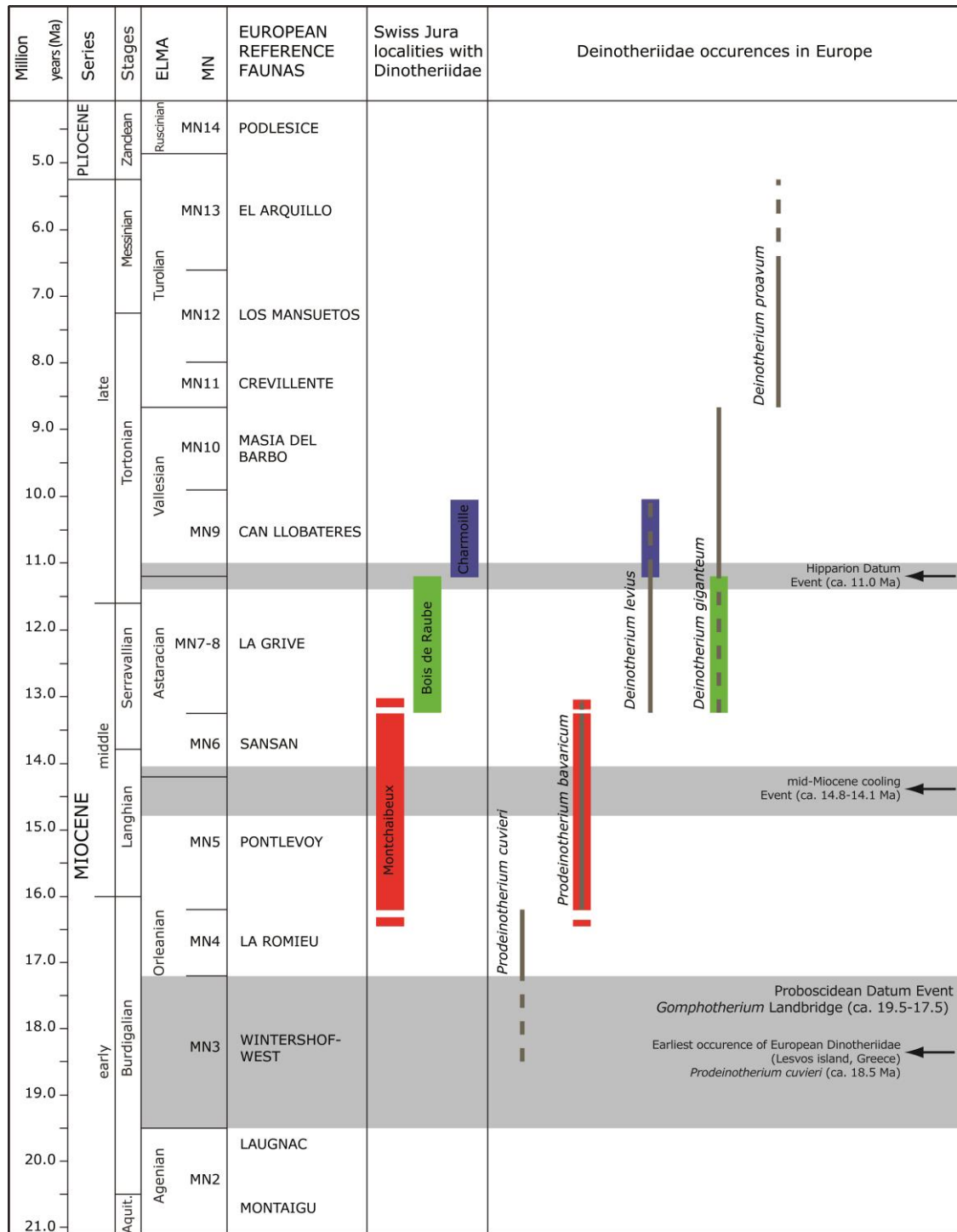

Figure 9. Stratigraphic extent of the five European species of Deinotheriidae (*P. cuvieri*, *P. bavaricum*, *D. levius*, *D. giganteum* and *D. proavum*). The dashed lines represent enlarged occurrences for each species, supported by the fossil record of the appendix. The correlations with the European fauna of reference are according to Berger (2011) and the ones with the regional lithostratigraphy according to Kälin (1993, 1997) and Prieto et al. (2017).

Biogeographic distribution of European Deinotheriidae

The deinotheres known since the Late Oligocene in Africa arrived later in Eurasia, following the mid-Burdigalian Proboscidean Datum Event (ca. 19.5-17.5 Ma). This event is related to the terrestrial corridor, called the *Gomphotherium* Landbridge, allowing a faunal exchange between Eurasia and the Arabian Plate of which the proboscideans were the palaeontological index fossils (Tassy 1990, Göhlich 1999, Rögl 1999a, b, Koufos et al. 2003). Although the first, short-lasting migration corridors evolved already during the Aquitanian or perhaps earlier in Asia (e.g. Tassy 1990, Antoine et al. 2003), the main wave of migration of the *Gomphotherium* Landbridge started during the mid-Burdigalian in Europe, with the arrivals of the earliest gomphotheres, deinotheres and mammutids at the end of MN3 (Tassy 1990, Koufos et al. 2003). Among the early occurrences of European deinotheres in MN3-4, *Prodeinotherium cuvieri* is mostly endemic to the west of Europe (France and Spain; Fig. 10) except for the earliest occurrence in Lesvos Island (MN3; identified as *P. bavaricum* in Koufos et al. 2003, but corrected as *P. cuvieri* following the concept of the five European species to be valid as Aiglstorfer et al. 2014, Konidaris et al. 2017 and Göhlich 2020) which is likely a record of the immigration itself. Later *P. bavaricum* presents a more balanced distribution all over Europe (Fig. 10). This period corresponds to the Miocene Climatic Optimum (ca. 17.0-15.0 Ma) when a tropical forest covered most of Europe with an average annual temperature that could reach 20-22°C and a more marked seasonality (nearly six months of drought; Böhme 2003).

In the MN6-8 interval, a fast climatic deterioration, in the form of an important fall of the temperature (Mid-Miocene Cooling Event, ca. 14.8-14.1 Ma; Flower & Kennett 1994), roughly coincides with the transition from the last *P. bavaricum* to the appearance of bigger deinotheres like *D. levius* and to a lesser degree *D. giganteum*, however with a distribution similar to that of *P. bavaricum*. From a climatic and environmental perspective, this period is also characterised by the desiccation of the sea in the east of Europe and the oriental regions of the Mediterranean (Eronen et al. 2010). The average annual temperature dropped by at least 7°C to settle between 15.4°C and 14.8°C mean annual temperatures. Meanwhile, the minimal temperatures for the coldest months go down by more than 11°C inducing freezing temperature during winters. This climatic deterioration also contributes to settle more contrasted climatic zones across Europe (Böhme 2003).

After the *Hipparion Datum Event* (ca. 11.0 Ma), i.e. arrival in Europe of the little tridactyl horse from northern America (*Hippotherium primigenium*) throughout the Holarctic regions (McFadden 1992), the deinotheres are essentially dominated by *D. giganteum* during the Vallesian (e.g. Göhlich 2020), although some rare occurrences *D. levius* are still reported (e.g. Göhlich & Huttunen 2009, this study), and the huge *D. proavum* during the Turolian (e.g. Konidaris et al. 2017). The occurrence of *Deinotherium* is also confirmed at the latter time into the Middle East with *D. proavum* (most likely

misidentified in *D. giganteum* by Mirzaie Ataabadi et al. 2011) and in India with *D. indicum* (Sankhyan & Sharma 2014, Singh et al. 2020).

Finally, during the MN13 biozone, corresponding to the Messinian Crisis (ca. 6.0-5.0 Ma) and the extension of the open forests in the temperate latitudes of Eurasia (Vislobokova & Sotnikova 2001, Rouchy and al. 2006), only the last representatives of *D. proavum* subsist in Eastern Europe (e.g. Gasparik 2001).



Figure 10. Palaeobiogeographic distribution of the five Deinotheriidae species in Europe (*Prodeinotherium cuvieri*, *P. bavaricum*, *Deinotherium levius*, *D. giganteum*, *D. proavum*), according to the localities written in appendix.

Morphological evolution and ecology of the Deinotheriidae

Teeth of Deinotheriidae show a remarkable increase of their dimensions throughout their evolution (Pickford & Pourabrishami 2013) which reflects an evolution toward larger size for the whole family

(Aiglstorfer et al. 2014, Codrea & Margin 2009). According to Agustí & Antón (2002), ~~the~~ *Prodeinotherium* was 2 metres tall at the shoulder, while *Deinotherium* might have reached 4 metres. Some species of Deinotheriidae presented body mass far greater than those of extant elephants. For comparison, the greatest recorded weight of an African elephant is 6.64 tons (Larramendi 2016), whereas the average ranges between 4 and 5 tons. The most ancestral deinotheres, *Chilgatherium harrisi*, weighed already 1.5 tonnes (Sanders et al. 2004), *Prodeinotherium bavaricum* and *P. hobleyi* weighed nearly 4 tonnes, *Deinotherium bozasi* about 9 tonnes, *D. levius* about 10 tonnes, while *D. giganteum* and *D. proavum* greatly exceeded 10 tonnes (Larramendi 2016). All the Deinotheriidae representatives are therefore mega herbivores, i.e. mammals that feed on plants and reach a body mass of at least a tonne or more at an adult age (Owen-Smith 1988). Throughout the evolution of terrestrial mammals, a maximal limit of body mass of the mega herbivores could be of approximately 17 tonnes, estimated weight for *Paraceratherium transouralicum* (Rhinocerotidae of the lower Oligocene in Eurasia) and some specimens of *Deinotherium* from the Late Miocene of Eurasia and Africa (Smith et al. 2010). Nowadays, mega herbivores include elephants, most of rhinoceros, hippopotamus and giraffes, however none of these mammals reach 10 tonnes (Owen-Smith 1988). The body size and mass of mammals is linked to a large number of physiological and ecological traits (Blueweiss et al. 1978, Brown et al. 2004). The lifestyle, the living environment and the spatial distribution of the species are parameters particularly linked to the size (for a synthesis see McNab 1990 and Eisenberg 1990). Having a large body size and mass brings consequently non-negligible advantages for the survival of a population, such as a lower mortality rate, a more stable population dynamic and a better resistance to sickness and limiting environment factors (Langer 2003, Erb et al. 2001). Among large mammals, the mega herbivores are more immunised against predation thanks to their huge size and mass, providing also a protection to the youngest because of their generally gregarious behaviour (Hummel & Clauss 2008). This advantage might have been particularly important during the Miocene that also sees a significant size augmentation of some predators (e.g., *Hyainailouros sulzeri*, *Amphicyon giganteus*, *Machairodus giganteus*; Agustí & Antón 2002). Due to the opening of environments during the Neogene (e.g. Suc et al. 1999, Favre et al. 2007, Costeur et al. 2007, Costeur & Legendre 2008), the folivore herbivores, such as the deinotheres, also had to browse over extended ranges from a wooded patch to another to find food. Large mammals have greater potential for long range dispersal and hence larger geographical distribution (e.g. Brown 1995, Gaston 2003), the displacements demanding less energy per distance unit for large animals (Owen-Smith 1988). More important size and mass were therefore favourable in the environmental context of the Miocene in Europe. Lastly, the appearance of the first really large European species of *Deinotherium* (*D. levius*, *D. giganteum*) occurred in the Middle Miocene, corresponding to the global fall of temperatures (Mid-Miocene Cooling Event, ca. 14.8-14.1 Ma; Flower & Kennett 1994).

According to the Bergmann's Law (Bergmann 1847, Blackburn & Hawkins 2004), although this rule suffers from numerous exceptions (Meiri & Dayan 2003), a large body mass also allows a limitation of heat loss and presents a significant advantage in a colder climate. All these advantages linked to large size and mass could have supported the natural selection of larger deinotheres and in turn could explain the regular augmentation of size of this family during the Neogene.

The structure of the cheek teeth of deinotheres is specifically bilophodont and closer to those of tapirs than the multilophodont (lamellae) structure of extant elephants. Tapirs are essentially folivores and spend up to 90% of their active time to feed on fruits, leaves, barks and flowers (Huttunen 2002a, Sanders 2018, Naranjo 2009). Likewise, deinotheres seem to be specialised in a regime consisting of dicotyledonous foliage and are generally linked to closed environmental patches (Calandra et al. 2008, Čkonjević & Radović 2012, Aiglstorfer and al. 2014). Additionally, the gradual size increase observed in deinotheres through time (e.g. Pickford & Pourabrishami 2013) seems to be associated to general evolution of environments in Europe: from rather closed forest environments of the Early and Middle Miocene and to rather open forest environments of the Late Miocene (Eronen & Rössner 2007).

In the more derived representatives of *Deinotherium*, the occiput is slightly inclined backwards and the occipital condyles elevated, characterizing a higher head posture (e.g. Harris 1973). The appendicular skeleton also presents a modification of the graviportal structure initially known in *Prodeinotherium* leading to a more agile anatomic type with notably a greater amplitude of movements for the anterior limbs (scapular spine without acromion and metacromion, functional tetradactyly with a reduction of the first metacarpal and first metatarsal; Huttunen 2002a). Therefore the association of the body size and mass and the anatomic evolution of Deinotheriidae suggests an ecological evolution at a family level, favouring the more mobile and larger species, adapted to more open and scattered forest landscapes. Such an evolutionary history could explain the progressive displacement of Deinotheriidae during the Miocene to Eastern Europe, where a drier climate (Eronen et al. 2010, Bruch et al. 2011) had probably favoured this type of environment.

Conclusion

During the MN4-6 interval, only the small-sized deinotheres (*Prodeinotherium* species) are present, mostly in Western Europe. The occurrence of large sizes is recorded since MN7 with the genus *Deinotherium*. This genus shows a gradual size increase through time (MN7/8 to MN13) from *D. levius* and *D. giganteum* to *D. proavum*. The last deinotheres are gradually restricted to Eastern



Europe, which seems to serve as a refuge area where eventually only the huge eventually *D. proavum* remain.

Two factors seems to explain this palaeobiogeographic dynamic, the climatic evolution during the Miocene leading to a differentiation between the environments of Western and of Eastern Europe, and the ecological evolution of the deinotheres. Since the beginning of the Miocene, Europe underwent numerous climatic changes that divided the continent in two really distinct environments from the Late Miocene onward. Indeed, Western Europe environments were dominated by still closed and semi-humid tropical forests whereas Eastern Europe had more open and drier forests landscapes due to a more continental climate (Vislobokova & Sotnikova 2001). Deinotheres being folivores were clearly linked to forest environments and needed large quantities of foliage throughout the year to sustain the amount of energy that their huge body mass required. The combination of their specialised diet and morphologic evolution (higher head posture, increased size and improved agility) reflects a remarkable adaptive and ecologic evolution of the family allowing their representatives to survive and flourish in Europe during the Miocene environmental transition. However, after having reached giant sizes and masses by the end of the Miocene, the extreme opening of the landscapes and the development of seasonal forests with deciduous leaves limiting the food supply (Kovar-Eder 2003, Suc et al. 1999, Jiménez-Moreno et al. 2010) could have initiated the disappearance of the family.

Acknowledgements

The authors express their gratitude to Loïc Costeur for giving them access to the collection of deinotheres hosted at the Natural History Museum of Basel and to Renaud Roch who produced copies of some of the specimens. We also thank Davit Vasilyan for his help finding studies published in Russian. Finally we are also grateful to the two reviewers, Martin Pickford and an anonymous one, whose comments helped us to improve this manuscript.

Additional information

Funding

This research was supported by two research grants from the Swiss National Foundation for Science (SNF-200021_162359 attributed to DB and OM, and SNF-CKSP_190584 attributed to OM)

Competing interests

The authors declare they have no personal or financial conflict of interest relating to the content of this study. OM is one of the *PCIPaleo* recommenders, but he was not involved in the peer review evaluation of this work.

Author contributions

FG and DB conceived the study. FG performed the initial description, prepared the graphic figures, performed the first analysis and interpretations of the data and wrote an initial draft. OM took the pictures of the specimens, prepared illustration plates. DB and OM corrected the dataset, completed the interpretations and revised the manuscript.

Supplementary information



The appendix contains a list of the European localities which yielded Deinotheriidae and the associated references. This dataset has been used to construct the figure 9. The appendix is available on Zenodo (doi: 10.5281/zenodo.4468801) [a reservation of the doi has been made on Zenodo and will be activated after acceptance of the Ms]

References

- Agustí J. & Antón M. 2002: *Mammoths, Sabertooths, and Hominids. 65 Million Years of Mammalian Evolution in Europe*. Columbia University Press, New York.
- Aiglstorfer M., Göhlich U.B., Böhme M. & Gross M. 2014: A Partial Skeleton of *Deinotherium* (Proboscidea, Mammalia) from the Late Middle Miocene Gratkorn Locality (Austria). *Palaeobiodiversity and Palaeoenvironments* 94, 49-70. doi.org/10.1007/s12549-013-0140-x
- Andrews C.W. 1911: On a New Species of *Dinotherium* (*Dinotherium hobleyi*) from British East Africa. *Proceedings of the Zoological Society of London* 81, 943-45. doi.org/10.1111/j.1096-3642.1911.tb01964.x
- Antoine P.O., Welcomme J.L., Marivaux L., Baloch I., Benammi M. & Tassy P. 2003. First record of Paleogene Elephantoidea (Mammalia, Proboscidea) from the Bugti Hills of Pakistan. *Journal of Vertebrate Paleontology* 23, 977-980.
- Arambourg C. 1934: Le *Dinotherium* des gisements de l'Omo (Abyssinie). *Bulletin de la Société géologique de France* 5, 305-310.

- Azanza B., Cerdeño E., Ginsburg L., van der Made J., Morales J. & Tassy P. 1993: Les grands mammifères du Miocène inférieur d'Artesilla, bassin de Calatayud-Teruel (Province de Saragosse, Espagne). *Bulletin du Muséum National d'Histoire Naturelle de Paris* 15, 105-153.
- Bachmann I. 1875: Beschreibung eines Unterkiefers v. *Dinotherium bavaricum*. *Abhandlungen der Schweizerischen paläontologischen Gesellschaft*, 2.
- Berger J.-P. 2011: Du bassin molassique au fossé rhénan: évolution des paléoenvironnements dans un avant-pays dynamique. *Géochronique, Magazine des Géosciences* 117, 44-49.
- Bergmann C. 1847: Über die Verhältnisse der Wärmeökonomie der Thiere zu ihrer Grösse, *Göttinger Studien*, 3, 595-708.
- Blackburn T.M., & Hawkins B.A. 2004: Bergmann's rule and the mammal fauna of northern North America, *Ecography*, 27, 715–724.
- Blueweiss L., Fox H., Kudzm, V., Nakashima D., Peters R. & Sams S. 1978: Relationships between body size and some life history parameters, *Oecologia*, 37(2), 257–272.
- Boev Z. & Spassov N. 2009: First record of ostriches (Aves, Struthioniformes, Struthionidae) from the late Miocene of Bulgaria with taxonomic and zoogeographic discussion. *Geodiversitas* 31(3), 493-507.
- Böhme M. 2003: The Miocene Climatic Optimum: Evidence from Ectothermic Vertebrates of Central Europe. *Palaeogeography, Palaeoclimatology, Palaeoecology* 195, 389-401. [doi.org/10.1016/S0031-0182\(03\)00367-5](https://doi.org/10.1016/S0031-0182(03)00367-5)
- Böhme M., Aiglstorfer M., Uhl D. & Kullmer O. 2012: The Antiquity of the Rhine River: Stratigraphic Coverage of the Dinotheriensande (Eppelsheim Formation) of the Mainz Basin (Germany). *PLoS ONE* 7, e36817.
- Bonaparte C.L.J.L. 1845: *Catalogo Metodico die Mammiferi Europei*. Coi tipi di L. di Giacomo Pirola, Milan.
- Brown J.H. 1995: *Macroecology*. The University of Chicago Press, Chicago.
- Brown J.H., Gillooly J.F., Allen A.P., Savage V.M. & West, G.B. 2004: Toward a metabolic theory of ecology, *Ecology*, 85(7), 1771–1789.
- Bruch A.A., Utescher T., & Mosbrugger V. 2011: Precipitation patterns in the Miocene of Central Europe and the development of continentality, *Palaeogeography Palaeoclimatology Palaeoecology*, 304, 202–211, doi.org/10.1016/j.palaeo.2010.10.002
- Calandra I., Göhlich U.B. & Merceron G., 2008. How could sympatric megaherbivores coexist? Example of niche partitioning within a proboscidean community from the Miocene of Europe. *Naturwissenschaften* 95, 831-838.

- Chaimanee Y., Suteethorn V., Jintasakul P., Vidthayanon C., Marandat B. & Jaeger J.-J. 2004: A New Orang-Utan Relative from the Late Miocene of Thailand. *Nature* 427, 439-41. doi.org/10.1038/nature02245
- Choffat K. & Becker D. 2017: Les grands mammifères du Miocène supérieur de Charmoille (Jura, Suisse). *Actes de la Société jurassienne d'émulation* 119, Porrentruy, 29-57.
- Čkonjević B. & Radović P. 2012: *Deinotherium giganteum* from Adrani, central Serbia. *Bulletin of the Natural History Museum* 5, 15-20.
- Codrea V. & Margin C. 2009: The environments of the uppermost Miocene vertebrates from Derșida (Northwestern Rumania, Sălaj county). Muzeul Olteniei Craiova. *Oltenia. Studii și comunicări. Științele Naturii*, Tom. XXV/2009.
- Codrea V., Fărcaș C., Săsăran E. & Dica P. 2002: Late Miocene mammal fauna from Derșida (Sălaj district) and its related paleoenvironment. *Studia Universitatis Babeș-Bolyai, Special issue* 1, 119-132.
- Costeur L., & Legendre S. 2008: Mammalian communities document a latitudinal environmental gradient during the Miocene optimum in western Europe, *Palaios*, 23, 280–288.
- Costeur L., Legendre S., Aguilar J.-P., & Lécuyer C. 2007: Marine and continental synchronous climatic records: Towards a revision of the European Mid-Miocene mammalian biochronological framework, *Geobios*, 40, 775–784.
- Duranthon F., Antoine P.O., Laffont D. & Bilotte M. 2007: Contemporanéité de *Prodeinotherium* et *Deinotherium* (Mammalia, Proboscidea) à Castelnaud-Magnoac (Hautes-Pyrénées, France). *Revue de Paléobiologie* 10, 403-411.
- Éhik J. 1930: *Prodeinotherium hungaricum* n. g., n. sp. *Geologica Hungarica, Series Palaeontologica* 6, 1-24.
- Eichwald K.E.I. 1831: *Zoologia specialis quam expositis animalibus tum vivis, tum fossilibus potissimum Rossiae in universum, et Poloniae in species* (3rd ed.). Typis Josephi Zawadzki, Vilna (Vilnius).
- Eisenberg J.F. 1990: The behavioral/ecological significance of body size in the Mammalia. In: Damuth J. & MacFadden B.J. (eds) *Body Size in Mammalian Paleobiology: Estimation and Biological Implications*. Cambridge University Press, Cambridge, pp 25-37.
- Engesser B. & Mödden C. 1997: A new version of the biozonation of the Lower Freshwater Molasse (Oligocene and Aagenian) of Switzerland and Savoy on the basis of fossil mammals. In: Aguilar J.-P., Legendre S. & Michaux J. (Eds.). *Actes du Congrès Biochrom'97*. Ecole pratique des hautes études-Sciences de la vie et de la terre - Institut de Montpellier, Montpellier, 475-499.
- Erb J., Boyce M.S. & Stenseth N.C. 2001: Population dynamics of large and small mammals, *Oikos*, 92, 3–12.

- Eronen J. & Rössner G.E. 2007: Wetland paradise lost: Miocene community dynamics in large herbivorous mammals from the German. Molasse Basin. *Evolutionary Ecology Research* 9, 471-494.
- Eronen J.T, Puolamäki K., Liu L., Lintulaakso K., Damuth J., Janis C. & Fortelius M. 2010: Precipitation and large herbivorous mammals, part II: Application to fossil data. *Evolutionary Ecology Research* 12, 235-248
- Falconer H. 1845: Description of some fossil remains of Dinotherium, giraffe, and other Mammalia, from the Gulf of Cambay, western coast of India, chiefly from the collection presented by Captain Fulljames, of the Bombay Engineers, to the Museum of the Geological Society. *Quarterly Journal of the Geological Society* 1, 356-372.
- Falconer H. 1868: On the European Pliocene and post-Pliocene species of the genus *Rhinoceros*. In: Murchison C. (Ed.). *Palaeontological Memoirs and Notes of the Late Hugh Falconer* vol. 2 (London), 309–403.
- Favre E., François L., Fluteau F., Cheddadi R., Thévenod L., & Suc J.-P. 2007: Messinian vegetation maps of the Mediterranean region using models and interpolated pollen data, *Geobios* 40, 433-443.
- Flower P.B. & Kennett J.P. 1994: The middle Miocene climatic transition: East Antarctic ice sheet development, deep ocean circulation and global carbon cycling. *Palaeogeography, Palaeoclimatology, Palaeoecology* 108, 537-555.
- Gasparik M. 1993: Deinotheres (Proboscidea, Mammalia) of Hungary. *Annales Historico-Naturales Musei Nationalis Hungarici* 85, 3-17.
- Gasparik M. 2001: Neogene proboscidean remains from Hungary; an overview. *Fragmenta Palaeontologica Hungarica* 19, 61-77.
- Gaston K.J. 2003: *The structure and dynamics of geographic ranges*. Oxford University Press, Oxford.
- Gheerbrant E. 2009: Paleocene Emergence of Elephant Relatives and the Rapid Radiation of African Ungulates. *Proceedings of the National Academy of Sciences* 106, 10717-10721. doi.org/10.1073/pnas.0900251106
- Gheerbrant E., Schmitt A. & Kocsis L. 2018: Early African Fossils Elucidate the Origin of Embrithopod Mammals. *Current Biology, Report* 28(13), 2167-2173. doi.org/10.1016/j.cub.2018.05.032
- Ginsburg L. & Chevrier F. 2001: Les dinothères du bassin de la Loire et l'évolution du genre *Deinotherium* en France. *Symbioses* n.s. 5, 9-24.
- Göhlich U.B. & Huttunen K. 2009: The early Vallesian vertebrates of Atzelsdorf (Late Miocene, Austria) 12. Proboscidea. *Annalen des Naturhistorischen Museums in Wien, Serie A* 111, 635-646.

- Göhlich U.B. 1999: Order Proboscidea. In: Rössner G.E. & Heissig K. (Eds.). *The Miocene Land Mammals of Europe*. Verlag Dr Friedrich Pfeil, München, 157-174.
- Göhlich U.B. 2020: The proboscidean fauna (Mammalia) from the middle Miocene lignites of Gračanica near Bugojno (Bosnia-Herzegovina). *Palaeobiodiversity and Palaeoenvironments* 100, 413-436.
- Gräf I.E. 1957: Die Prinzipien der Artbestimmung bei *Deinotherium*. *Palaeontographica* 180 (A), 131-185.
- Greppin J.-B. 1867: *Essai géologique sur le Jura suisse*. Helg & Boéchat, Delémont.
- Greppin J.-B. 1870: Description géologique du Jura bernois. *Matériaux pour la carte géologique de la Suisse* 8, 1-357.
- Harris J.M. 1973: *Prodeinotherium* from Gebel Zelten, Libya. *Bulletin of the British Museum (Natural History), Geology*, 23, 285-350.
- Harris J.M. 1978: Deinotherioidea and Barytherioidea. In: Coppens V. J. & Cooke H.B.S. (Eds.). *Evolution of African Mammals*. Harvard University Press, Cambridge, 315-332.
- Harris J.M. 1983: *The Fossil Ungulates: Proboscidea, Perissodactyla and Suidae. Koobi Fora Research Project (vol 2)*. Clarendon Press, Oxford.
- Harris J.M., Brown F.H. & Leakey M.G. 1988: Stratigraphy and paleontology of Pliocene and Pleistocene localities west of Lake Turkana, Kenya. *Natural History Museum of Los Angeles County, Contribution in Science* 399, 1-128.
- Hilgen F.J., Lourense L.J. & Van Dam J.A. 2012: The Neogene period. In: Gradstein F.M., Ogg J.G., Schmitz M.D. & Ogg G.M. (Eds.). *The Geologic Time Scale 2012. Volume 2*. Elsevier, Oxford, 923–978.
- Hummel J. & Clauss M. 2008: Megaherbivores as pacemakers of carnivore diversity and biomass: distributing or sinking trophic energy? *Evolutionary Ecology Research* 10, 925-930.
- Hutchinson J. R., Delmer C., Miller C. E., Hildebrandt T., Pitsillides A.A. & Boyde A. 2011: From Flat Foot to Fat Foot: Structure, Ontogeny, Function, and Evolution of Elephant “Sixth Toes”. *Science* 334, 1699-1703. doi.org/10.1126/science.1211437
- Huttunen K. 2002a: Systematics and Taxonomy of the European Deinotheriidae (Proboscidea, Mammalia). *Annalen des Naturhistorischen Museums in Wien* 103 A, 237-250.
- Huttunen K. 2002b: Deinotheriidae (Proboscidea, Mammalia) dental remains from the Miocene of Lower Austria and Burgenland. *Annalen des Naturhistorischen Museums in Wien* 103 A, 251-285.
- Huttunen K. & Göhlich U.B. 2002: A partial skeleton of *Prodeinotherium bavaricum* (Proboscidea, Mammalia) from the middle Miocene of Unterzolling (Upper Freshwater Molasse, Germany). *Geobios* 35, 489-514.

- Illiger C.D. 1811: Prodomus systematis mammalium et avium additis terminis zoographicis classis. Salfeld, Berlin.
- Jiménez-Moreno G., Fauquette S., & Suc J.-P. 2010: Miocene to Pliocene vegetation reconstruction and climate estimates in the Iberian Peninsula from pollen data, *Review of Palaeobotany and Palynology*, 162, 403–415. doi.org/10.1016/j.revpalbo.2009.08.001
- Jourdan M. 1861: Restes fossiles de deux grands mammifères. *Annales des sciences naturelles* 16 (4), 369-374.
- Kälin D. 1993: *Stratigraphie und Säugetierfaunen der oberen Süßwassermolasse der Nordwestschweiz*. Thèse inédite de l'université de Zurich, 238 p.
- Kälin D. 1997: Litho- und Biostratigraphie der mittel- bis obermiozänen Bois de Raube-Formation (Nordwestschweiz). *Eclogae Geologicae Helvetiae* 90, 97-114.
- Kaup J.J. 1829: Neues Säugthier, *Deinotherium*: *Deinotherium giganteum*. *Isis* 22 (4), 401–404.
- Kaup J.J. 1832: Description d'ossements fossiles de mammifères inconnus jusqu'à présent, qui se trouvent au Muséum grand-ducal de Darmstadt. J.G. Heyer, Darmstadt.
- Konidaris G.E. & Koufos G.D. 2019: Late Miocene proboscideans from Samos Island (Greece) revisited: new specimens from old collections. *Paläontologische Zeitschrift* 93, 115-134.
- Konidaris G.E., Roussiakis S.J., Athanassiou A. & Theodorou G.E. 2017: The huge-sized Deinothere *Deinotherium proavum* (Proboscidea, Mammalia) from the Late Miocene Localities Pikermi and Halmyropotamos (Greece). *Quaternary International* 445, 5-21. doi.org/10.1016/j.quaint.2017.07.038
- Koufos G.D., Zouros N. & Mourouzidou O. 2003: *Prodeinotherium bavaricum* (Proboscidea, Mammalia) from Lesbos Island, Greece; the Appearance of Deinotheres in the Eastern Mediterranean. *Geobios* 36, 305-15. doi.org/10.1016/S0016-6995(03)00031-7
- Kovachev D. & Nikolov I. 2006: *Deinotherium thraceiensis* sp. nov. from the Miocene near Ezerovo, Plovdiv District. *Geologica Balcanica* 35 (3–4), 5-40.
- Kovar-Eder, J. 2003: Vegetation dynamics in Europe during the Neogene, *Deinsea*, 10, 373-392.
- Langer P. 2003: Lactation, weaning period, food quality, and digestive tract differentiations in Eutheria, *Evolution*, 57(5), 1196-1215.
- Larramendi A. 2016: Proboscideans: Shoulder Height, Body Mass and Shape. *Acta Palaeontologica Polonica* 61, 537-574. doi.org/10.4202/app.00136.2014
- Liniger H. 1925: Geologie des Delsberger Beckens und der Umgebung von Movelier. *Beiträge zur Geologischen Karte der Schweiz* 55, 1-71.
- Linnaeus C. 1758: *Systema Naturae per regna tria naturae, secundum classes, ordines, genera, species, cum characteribus, differentiis, synonymis, locis. Vol. 1: Regnum animale*. 10th edition, Stockholm.

- McFadden B.J. 1992: *Fossil Horses. Systematics, Paleobiology, and Evolution of the Family Equidae*. Cambridge University Press, Cambridge, New York, Melbourne, Madrid.
- Maridet O. & Costeur L. 2010: Diversity Trends in Neogene European Ungulates and Rodents: Large-Scale Comparisons and Perspectives. *Naturwissenschaften* 97 (2), 161-72. doi.org/10.1007/s00114-009-0623-9
- Markov G.N. 2008: The Turolian proboscideans (Mammalia) of Europe: preliminary observations. *Historia naturalis bulgarica* 19, 153-178.
- McNab, B. 1990: The physiological significance of body size. In: Damuth J, MacFadden BJ (eds) *Body Size in Mammalian Paleobiology: Estimation and Biological Implications*, Cambridge University Press, Cambridge, pp 11–24.
- Mein P. 1999: European Miocene Mammal Biochronology. In: Rössner G.E. & Heissig K. (Eds.). *The Miocene Land Mammals of Europe*. Verlag D^r Friedrich Pfeil, München, 25-38.
- Meiri S. & Dayan T. 2003: On the validity of Bergmann's rule: *Journal of Biogeography*, v. 30, p. 331–351. doi.org/10.1046/j.1365-2699.2003.00837.x
- Meyer H. von. 1831: Mittheilung an geheimen Rath von Leonhard. *Jahrbuch für Mineralogie* 1831, 296-297.
- Mirzaie Ataabadi M., Mohammadalizadeh J., Zhang Z., Watabe M., Kaakinen A. & Fortelius M. 2011: Late Miocene large mammals from Ivand (Northwestern Iran). *Geodiversitas* 33, 709-728.
- Naranjo E.J. 2009: Ecology and conservation of Baird's tapir in Mexico. *Tropical Conservation Science* 2, 140-158. doi.org/10.1177/194008290900200203
- Owen-Smith N. 1988: *Megaherbivores: The Influence of Very Large Body Size on Ecology*. Cambridge University Press, Cambridge.
- Pickford M. & Pourabrishami Z. 2013: Deciphering Dinotheriensande deinotheriid diversity. *Palaeobiodiversity and Palaeoenvironments* 93 (2): 121-150. doi.org/10.1007/s12549-013-0115-y
- Pickford M. 2003: New Proboscidea from the Miocene strata in the lower Orange River Valley, Namibia. *Memoir of the Geological Survey of Namibia* 19, 207-256.
- Poulakakis N., Lymberakis P. & Fassoulas C. 2005: Reviewed work(s). *Deinotherium giganteum* (Proboscidea, Deinotheriidae) from the Late Miocene of Crete. *Journal of Vertebrate Paleontology* 25, 732-36.
- Prieto J., Becker D., Rauber G. & Pirkenseer C.M. 2017: New Biostratigraphical data for the Burdigalian Montchaibeux Member at the Locality Courrendlin-Solé (Canton of Jura, Switzerland). *Swiss Journal of Geosciences* 111, 1-11. doi.org/10.1007/s00015-017-0285-0
- Rai Y.C. 2004: Fossil elephants from the Indian sub-continent and their tusks: A review. *Journal Palaeontological Society of India* 49, 169-188.

- Rögl F. 1999a: Mediterranean and Paratethys. Facts and hypotheses of Oligocene to Miocene palaeogeography (short overview). *Geologica Carpathica* 50, 339-349.
- Rögl F. 1999b: Circum-Mediterranean Miocene palaeogeography. In: Rössner G.E. & Heissig K. (Eds.). *The Miocene Land Mammals of Europe*. Verlag D^r Friedrich Pfeil, München, 39-48.
- Rouchy J.M., Suc J.P., Ferrandini J. & Ferrandini M. 2006: The Messinian Salinity Crisis revisited. *Sedimentary Geology*, 188-189, 1-8.
- Sanders W.J. 2018: Proboscidea from Kanapoi, Kenya. *Journal of Human Evolution*, S0047248418303919. doi.org/10.1016/j.jhevol.2018.10.013
- Sanders W.J., Kappelman J. & Rasmussen D.T. 2004: New large-bodied mammals from the late Oligocene site of Chilga, Ethiopia. *Acta Paleontologica Polonica* 49 (3), 365–392. <http://www.app.pan.pl/archive/published/app49/app49-365.pdf>
- Sanders W.J., Gheerbrant E., Harris J.M., Saegusa H. & Delmer C., 2010: Proboscidea. In: Werdelin, L. & Sanders, W.J. (Eds.). *Cenozoic mammals of Africa*. University of California Press, Berkeley, 161-251.
- Sankhyan A.R. & Sharma S.L. 2014: *In situ* dental remains of *Deinotherium* from northwest Indian Siwalik. *Himalayan Geology* 35 (1), 75-81.
- Schäfer H. 1961: Die pontische Säugetierfauna von Charmoille (Jura bernois). *Eclogae Geologicae Helvetiae* 54, 559-566.
- Sen S. 2013: Dispersal of African Mammals in Eurasia during the Cenozoic: Ways and Whys. *Geobios* 46, 159-72. doi.org/10.1016/j.geobios.2012.10.012
- Singh N.P., Jukar A.M., Patnaik R., Sharma K.M., Singh N.A. & Singh Y.P. 2020: The first specimen of *Deinotherium indicum* (Mammalia, Proboscidea, Deinotheriidae) from the late Miocene of Kutch, India. *Journal of Paleontology*. [doi: 10.1017/jpa.2020.3](https://doi.org/10.1017/jpa.2020.3)
- Sissingh W. 2006: Syn-kinematic palaeogeographic evolution of the West European Platform: correlation with Alpine plate collision and foreland deformation. *Netherlands Journal of Geosciences* 85, 131–180.
- Smith F.A., Boyer A.G., Brown J.H., Costa D.P., Dayan T., Ernest S.K.M. & Evans A.R. 2010: The Evolution of Maximum Body Size of Terrestrial Mammals. *Science* 330, 1216-1219. doi.org/10.1126/science.1194830
- Stehlin H.G. 1914: Übersicht über die Säugetiere der schweizerischen Molasseformation, ihre Fundorte und ihre stratigraphische Verbreitung. *Verhandlungen der Naturforschenden Gesellschaft in Basel* 25, 170-193.
- Steininger F.F. 1999: Chronostratigraphy, Geochronology and Biochronology of the Miocene “European Land Mammal Mega-Zones (ELMMZ)” and the Miocene “Mammal-Zones (MN-

- Zones)". In: Rössner G.E. & Heissig K. (Eds.). *The Miocene Land Mammals of Europe*. Verlag Dr Friedrich Pfeil, München, 9-24.
- Suc J.-P., Fauquette S., Bessedik M., Bertini A., Zheng Z., Clauzon G., Suballyova D., Diniz F., Quézel P., Feddi N., Clet M., Bessais E., Taoufiq N.B., Méon H. & Combourieu-Nebout N. 1999: Neogene vegetation changes in West European and West circum-Mediterranean areas. In: Agusti, J., Rook, L. & Andrews, P. (Eds.). Hominoid Evolution and Climatic Change in Europe, Volume1. *The Evolution of Neogene Terrestrial Ecosystem in Europe, Hominid Evolution and Climate in Europe*. Cambridge, pp. 378-388.
- Svistun V.I. 1974: *Dinotheriums of Ukraine* [in Russian]. Naukovka dumka, Kiev.
- Tassy P. 1990: The Proboscidean Datum Event: How Many Proboscideans and How Many Events? In: Lindsay E.H., Fahlbusch V. & Mein P. (Eds.). *European Neogene Mammal Chronology*. Springer US, Boston, MA, 237-252.
- The Paleobiology Data Base. [data extracted on the 09.08.2019]. URL: <https://paleobiodb.org/navigator/>
- Țibuleac P. 2018: Two Medium-Sized Deinotheres (Proboscidea: Mammalia) from the Miocene Rocks of the Eastern Carpathians Foreland (Romania). *Geological Quarterly* 62 (3), 669-684. <https://doi.org/10.7306/gq.1430>
- Tobien H. 1988: Contributions à l'étude du gisement miocène supérieur de Montredon (Hérault). Les grands mammifères. 7 Les proboscidiens Deinotheriidae. *Palaeovertebrata* Mémoire extraordinaire 1988, 135-175.
- Vergiev S. & Markov G.N. 2010: A mandible of *Deinotherium* (Mammalia: Proboscidea) from Aksakovo near Varna, Northeast Bulgaria. *Palaeodiversity* 3, 241-247.
- Vislobokova I.A. & Sotnikova M.V. 2001: Pliocene faunas with Proboscideans of the Former Soviet Union. In: Cavaretta G., Gioia P., Mussi M. & Palombo M.R. (Eds.). *The World of Elephants*. Proceedings of the 1st International Congress, Consiglio Nazionale delle Ricerche - Roma, 157-160.
- Welcomme J.L., Antoine P.-O., Duranthon F., Mein P. & Ginsburg L. 1997: Nouvelles découvertes de vertébrés miocènes dans le synclinal de Dera Bugti (Balouchistan, Pakistan). *Comptes Rendus de l'Académie des Sciences. Sciences de la Terre et des Planètes* 325, 531-536.